

Solar Energy for In-Situ Resource Utilization

Takashi Nakamura
Physical Sciences Inc.
2110 Omega Road/Suite D
San Ramon, CA 94583

Space Resource Roundtable VI
Golden, Colorado

1-3 November 2004

Lunar-Based Solar Material Processing Plant

VG04-257-2

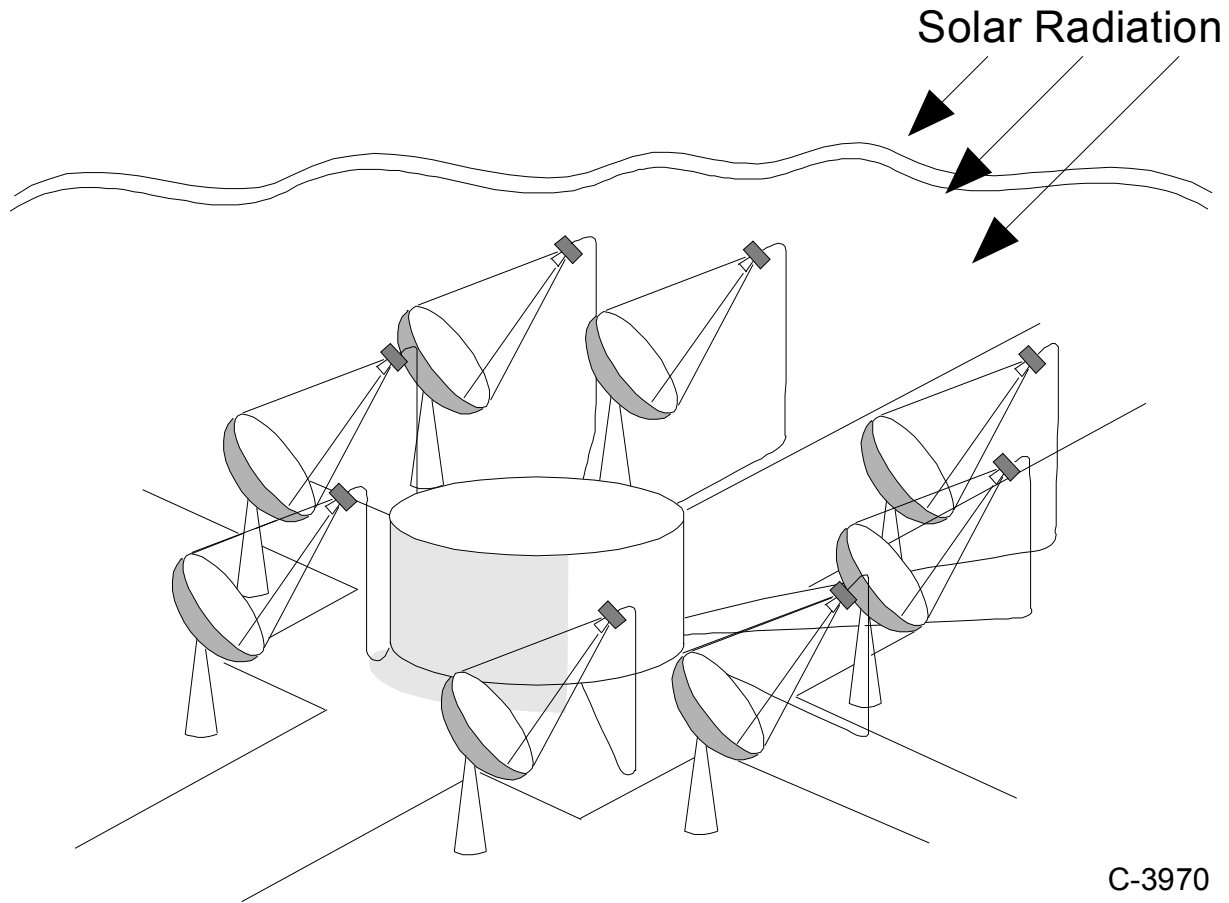

C-3970



Schematic Representation of the OW Solar Energy System for Lunar Materials Processing

VG04-257-3

Steerable Secondary Concentrators

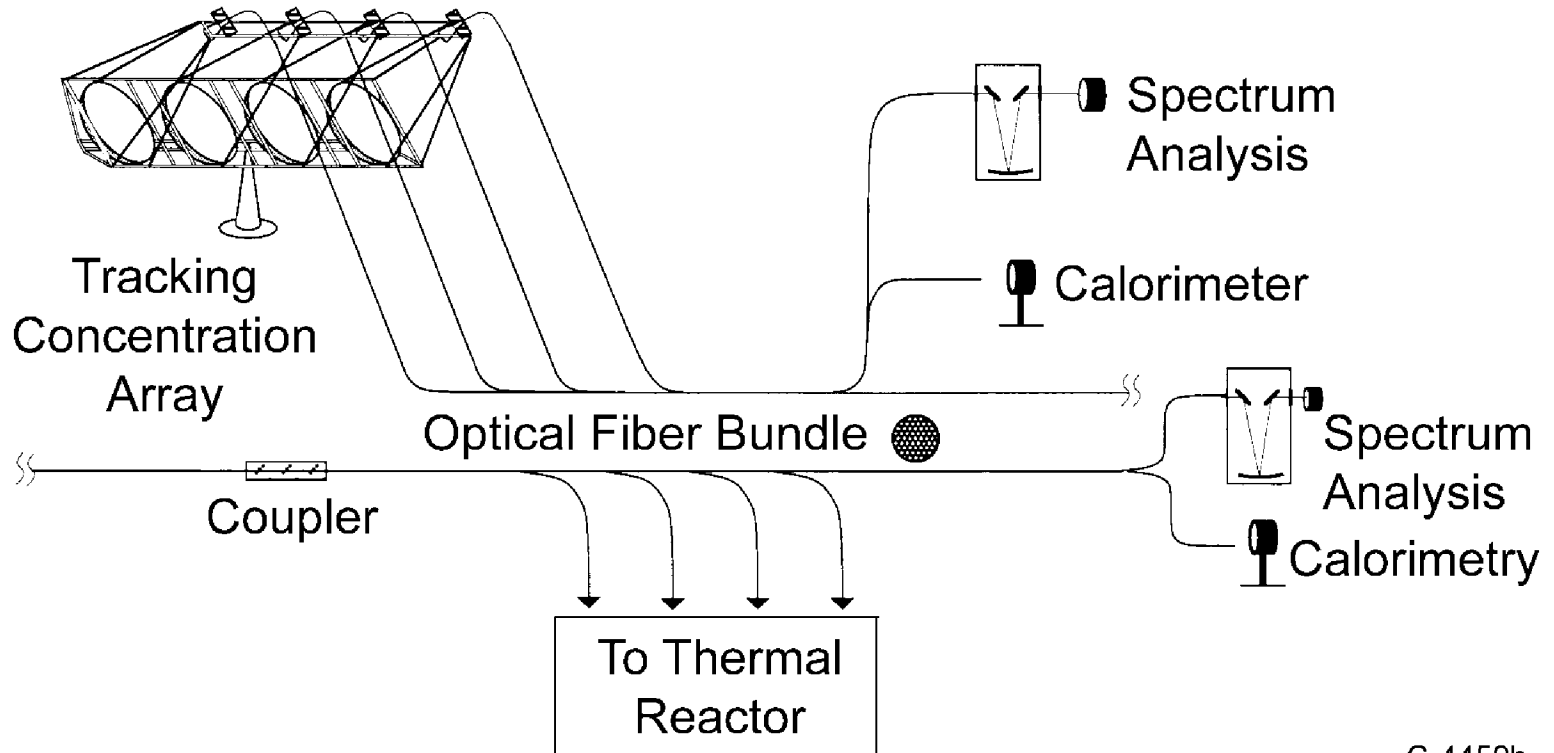

C-4459b

The Ground Test Model of the OW Solar Thermal Power System

VG04-257-4



ESI

PROCESSES

Thermal Reactor for Hydrogen Reduction of JSC-1

VG04-257-5

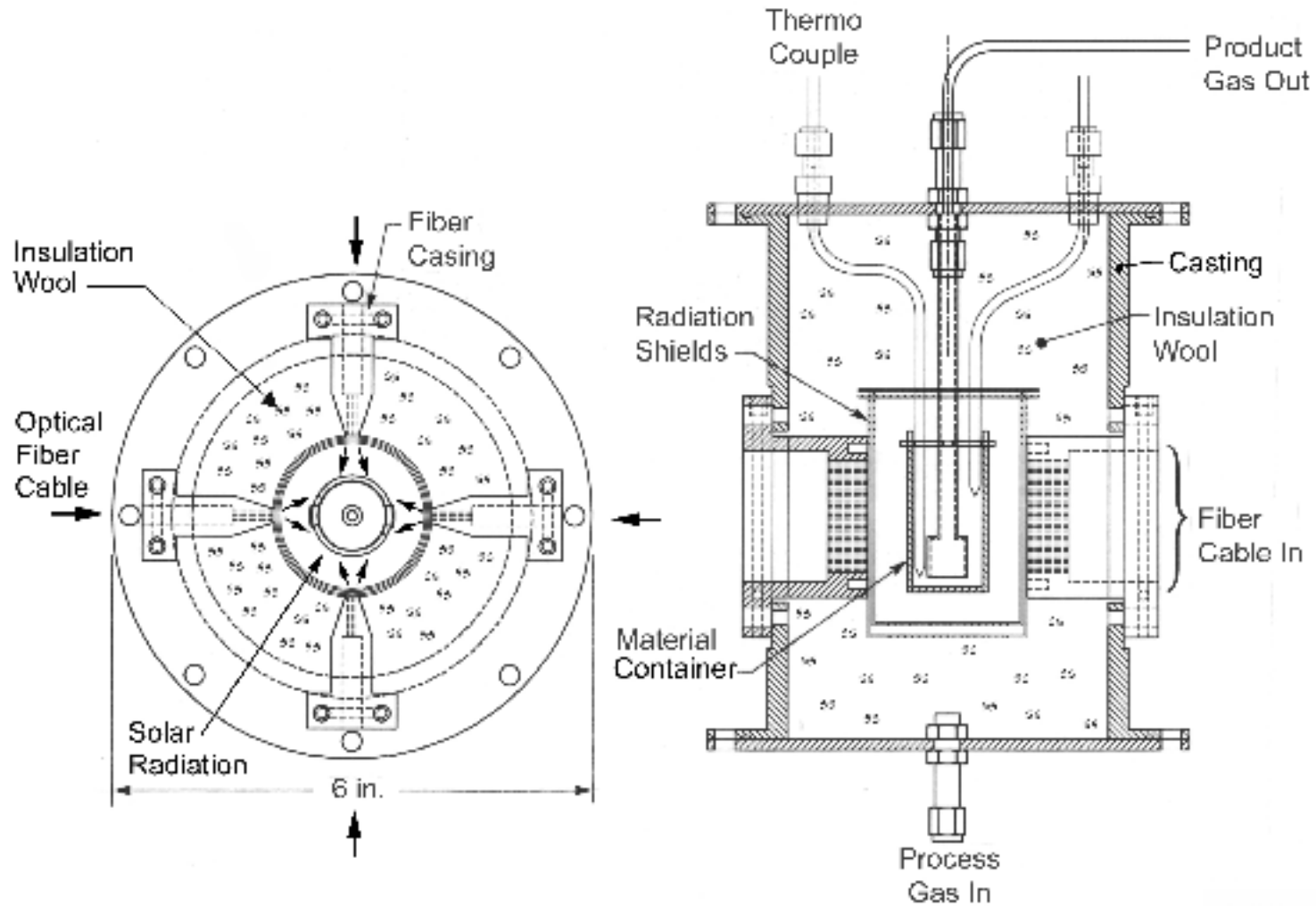

U-0002a



Thermal Reactor with Optical Fiber Cables

VG04-257-6



W-1173



Inside of Thermal Reactor

VG04-257-7



V-1091

ISI

PHYSICAL SCIENCES

Material Processing Container

VG04-257-8

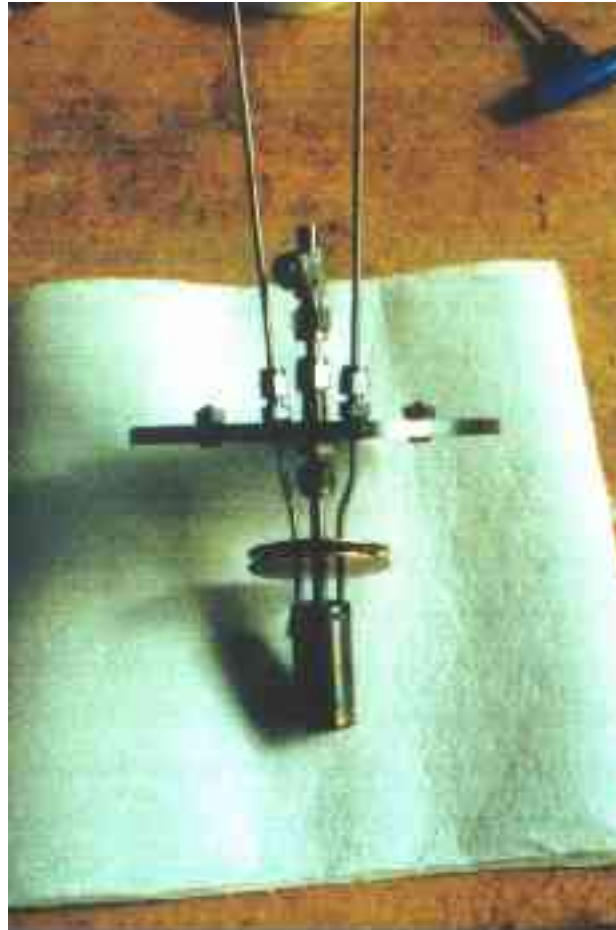

14-00002

ESI

PROCESSES

Material Processing Container: Schematic

VG04-257-9

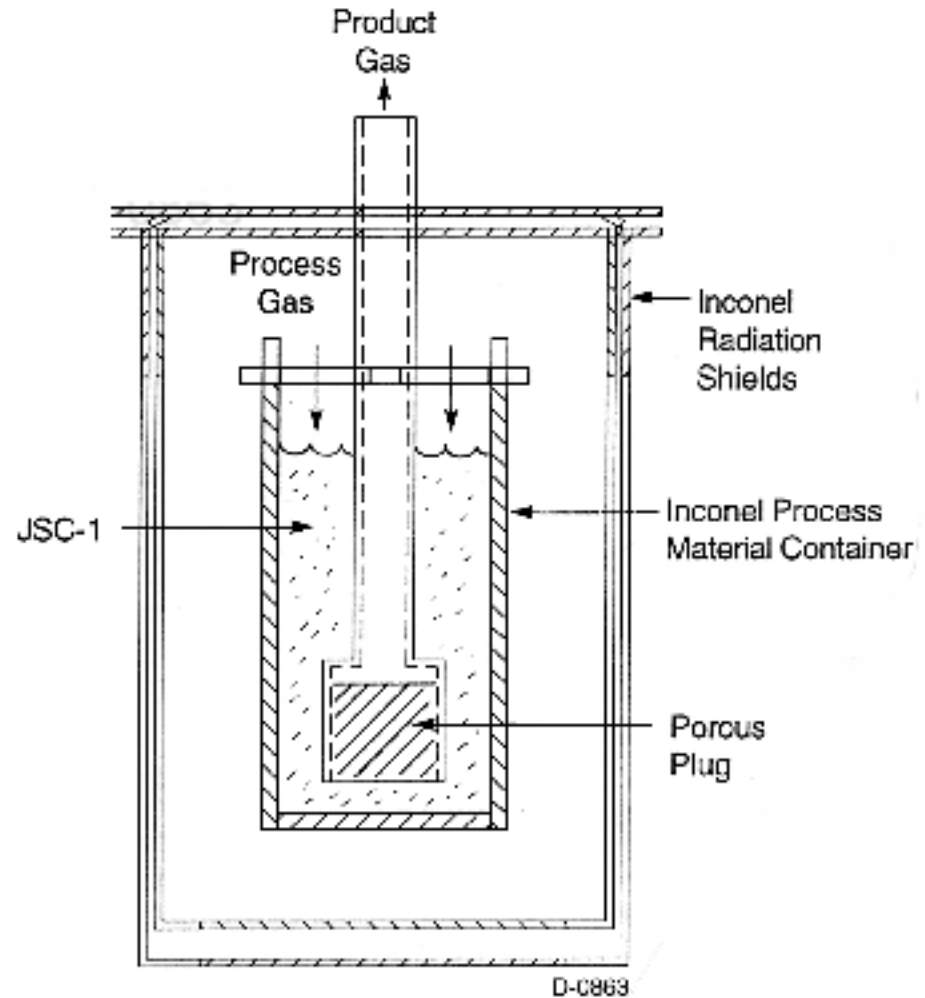
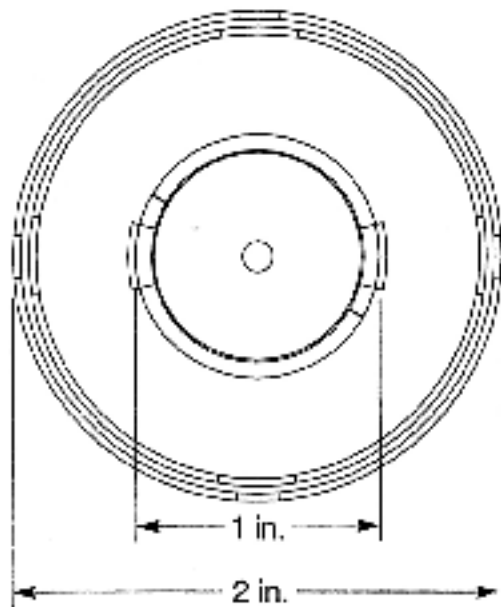

Material Processing Experiment

VG04-257-10

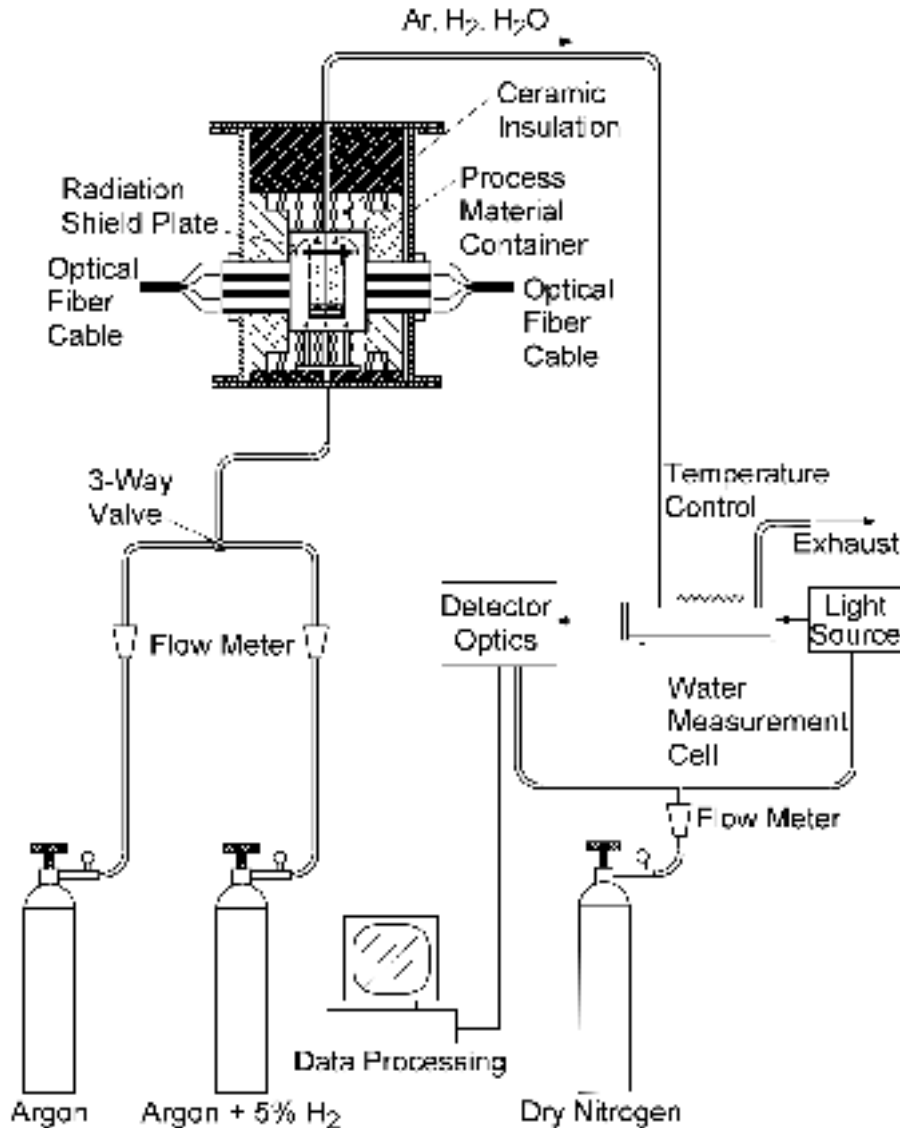

Hydrogen reduction of iluminite:

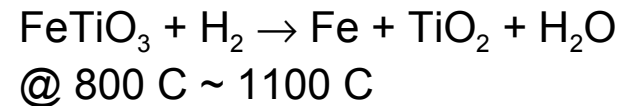

Material sample:

Lunar soil simulant (JSC-1)
containing 3 wt% of iluminite

Reaction detection:

Absorption of a water line at 1.36 μm

Thermal Reactor Temperature versus Solar Power

VG04-257-11

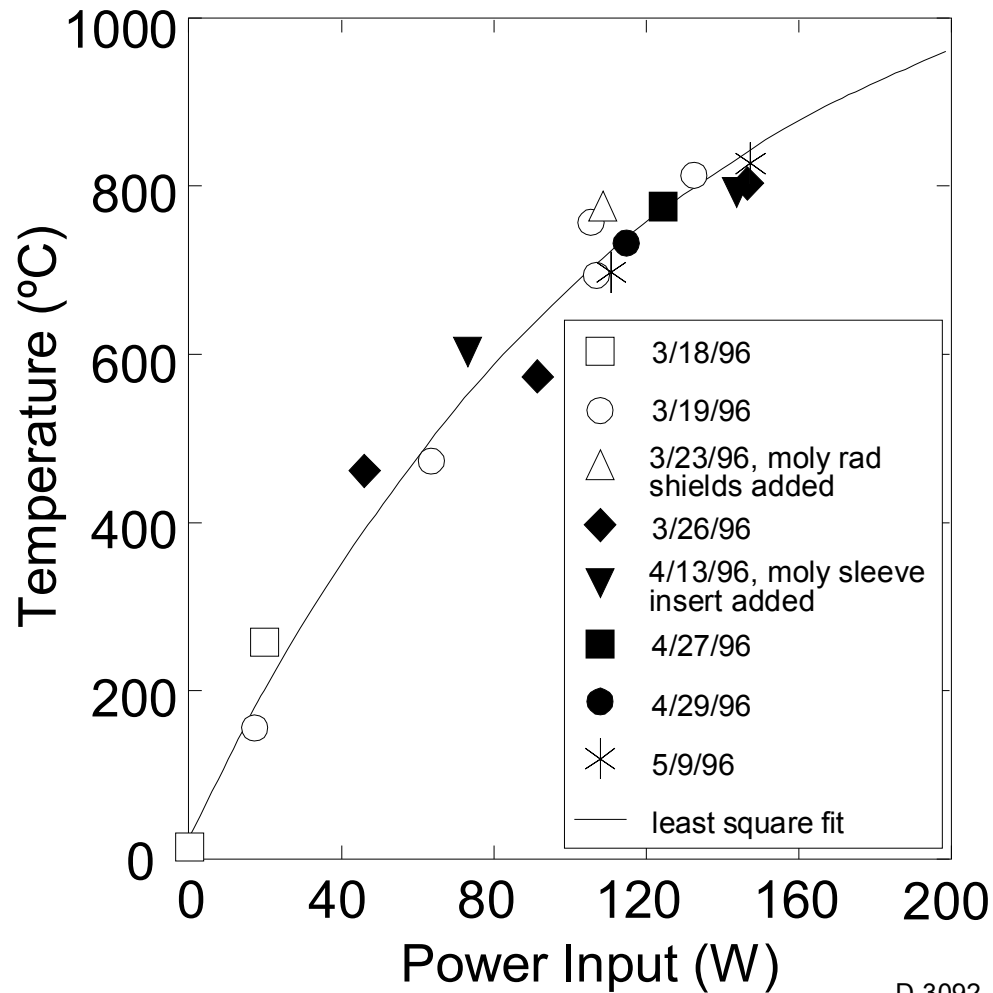

D-3092

Hydrogen Reduction of Ilmenite ($FeTiO_3$)

VG04-257-12

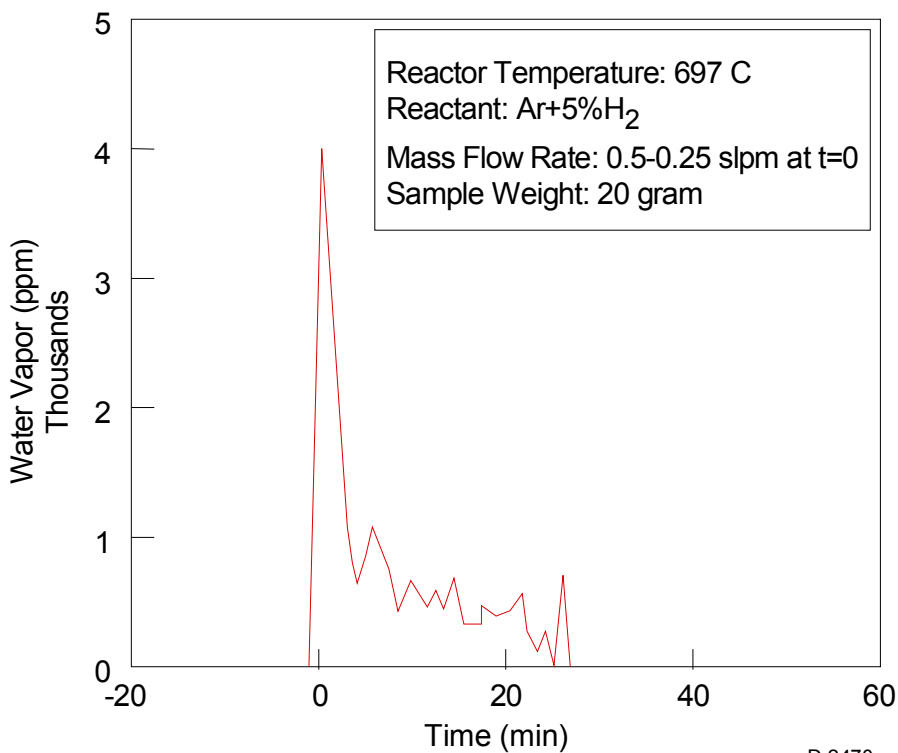

D-2470z

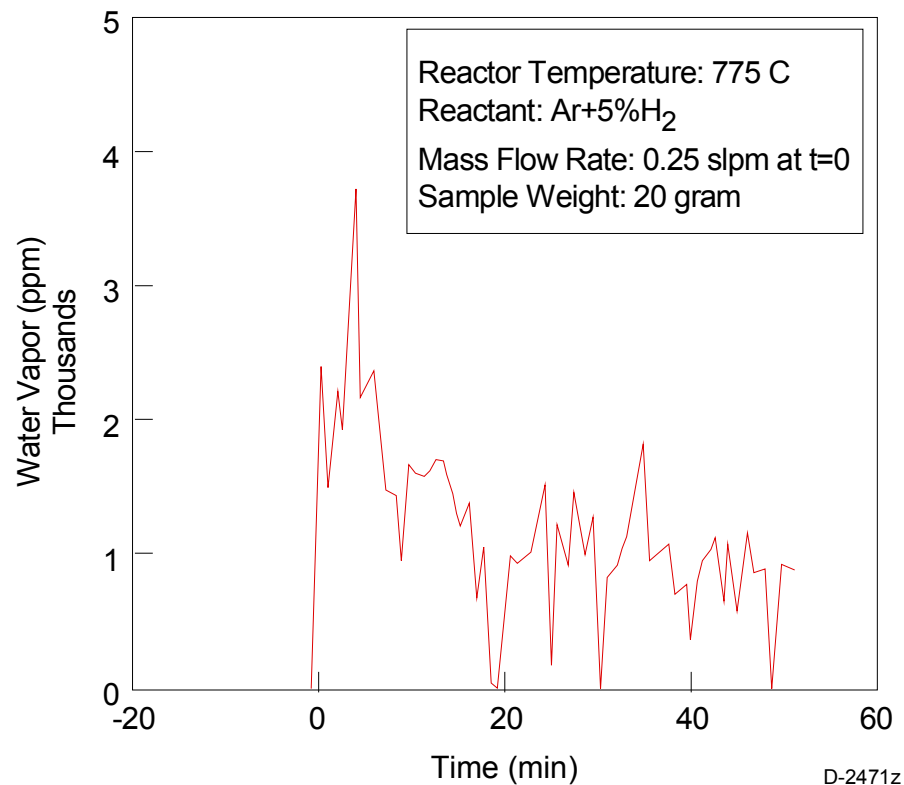

D-2471z



Hydrogen Reduction of JSC-1

VG04-257-13

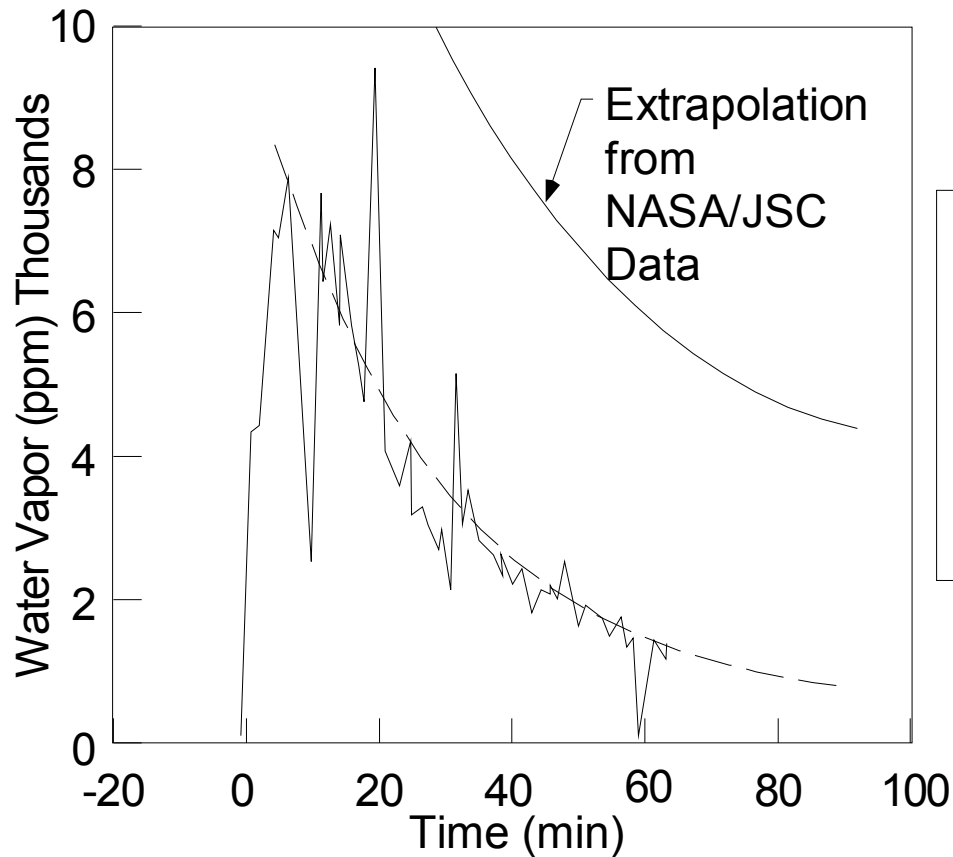

- Reactor Temperature: 832 C
- Reactant: Ar+5%H₂
- Sample Weight: 20 gram
- Mass Flow Rate: 0.25 slpm
at t=0
- Dotted Line: Least Squares
Curve Fit

D-2473a



System Efficiency of the Engineering Model and the Future Space Based System

VG04-257-14

	Engineering Model Results	Space-Based Operational System	Improvement Measures
Primary concentrator	0.722	0.864	
Reflectivity	0.82	0.90	<ul style="list-style-type: none"> • Reflectivity enhancing coating • Intercept factor in space will be higher
Intercept factor	0.88	0.96	
Concentrator fiber coupling	0.708	0.965	
Front-end Fresnel reflection	0.965	0.965	
Fiber fill factor	0.734	1.00	<ul style="list-style-type: none"> • Improve fiber cable front termination design for higher fill factor
Optical fiber cable transmitter (10 meter)	0.743	0.868	
Fiber transmission	0.77	0.90	<ul style="list-style-type: none"> • Use low-OH fiber for higher transmission efficiency
Back-end Fresnel reflection	0.965	0.965	
System efficiency	~0.380	~0.724	

Achievable Temperature versus Solar Flux Intensity

VG04-257-15

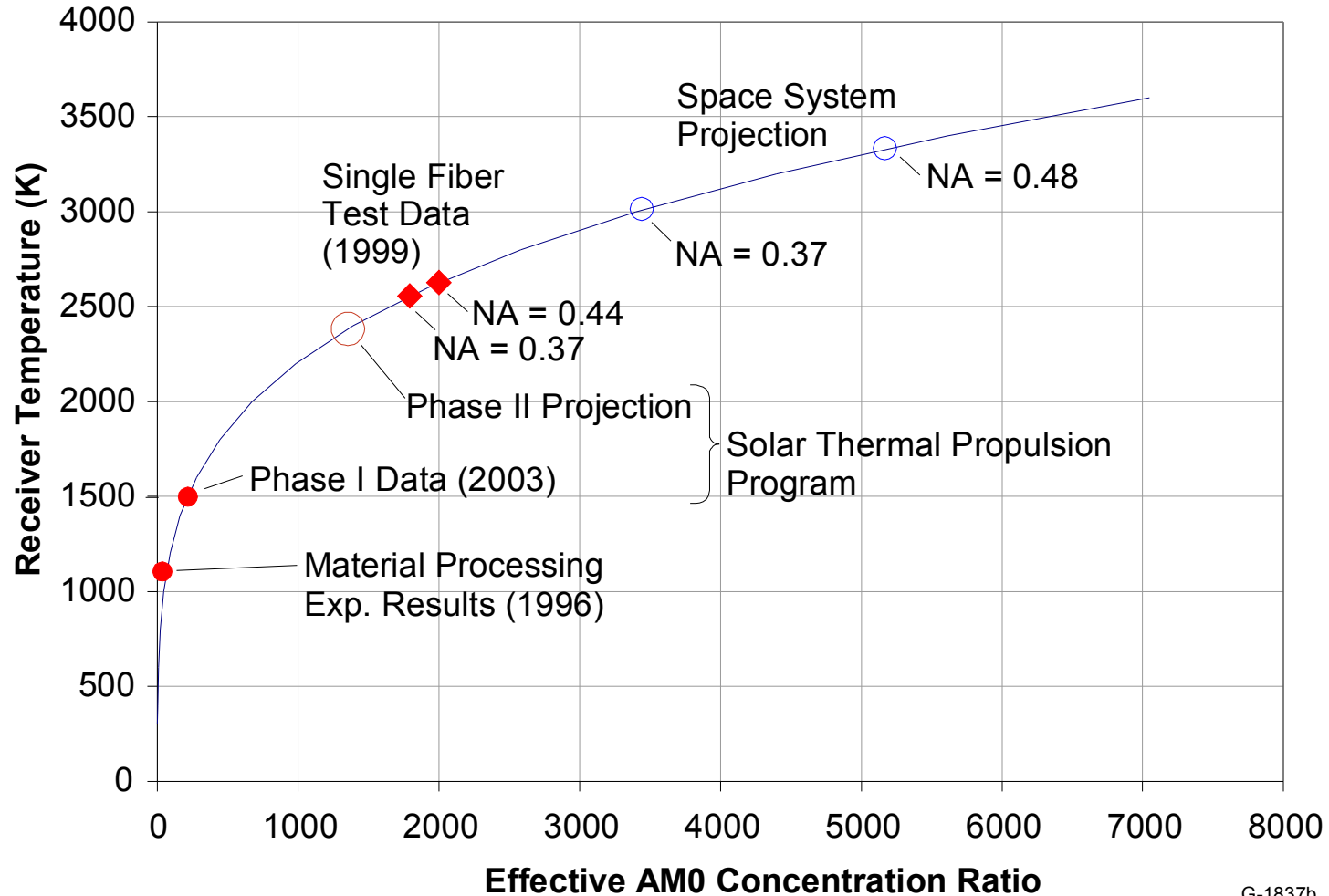

G-1837b



Optical Fiber Cables Emitting Solar Power

VG04-257-16



G-5027

ESI

PHOTOGRAPHY

High Temperature Processes for Lunar ISRU

VG04-257-17

Class		Description	Examples	Temperature [K]
Chemical Process Recovery	1	Pyrolysis	O ₂ production at low to medium pressure	2000-2500
	2	Gas-solid reactions	Reduction of regolith to produce O ₂	1000-1200
	3	Gas-liquid or three-phase reactions	Reduction of magma to produce O ₂ , silicates	1600-1800
	4	Desorption of solids	Solar wind volatiles, drying	1000-1200
Manufacturing	5	Hot liquid processing	Metal/basalt casting, glass processing	1200-1800
	6	Sinter forming	Powder metallurgy, refractory sintering	900-1800
	7	Composite forming	Fibers, whiskers, flakes in matrix	900-1800
	8	Welding/Glass blowing		1600-1800
Power Operations	9	Thermal energy storage	In fused basalt	< 1400



Conclusions

VG04-257-18

- **The Optical Waveguide System is capable of collection, concentration, and transmission of solar energy for in-situ resource utilization**
- **The overall system efficiency for the engineering model was 38%. It is expected that twice as high an efficiency (~72%) can be achieved for a space-based operation system**
- **This system can be applied to a variety of high temperature chemical processes, manufacturing processes, and power generation and storage**
- **Technology issues for the future includes:**
 - lightweight concentrator system
 - lightweight and efficient optical fiber cable
 - material processing solar reactor



Acknowledgements

VG04-257-19

This research was supported by NASA/JSC through Contracts NAS9-18865 and NAS9-19105

